

IoT-Enabled Monitoring and Notification System for Real-Time Water Quality Management

Herlina Abdul Rahim^{1*}, Syahzanani Zawannah Abdul Taip¹, Nur Athirah Syafiqah Noramli² and Aisyah Mohd Akram³

¹Faculty of Electrical Engineering, Universiti Teknologi Malaysia, Skudai, Johor, Malaysia

²College of Engineering, Universiti Teknologi MARA, Shah Alam, Selangor, Malaysia

³Regional Development & Strategy, Siemens Energy, Cyberjaya, Selangor

Corresponding author* email: herlina@utm.my

Available online 01 March 2026

ABSTRACT

River water pollution is a critical issue in Malaysia, posing health and environmental risks. This study presents a real-time monitoring and alert system integrating pH, turbidity, and temperature sensors with IoT technology. Using ESP32 hardware, sensor data were transmitted to ThingSpeak for visualization and logging, while SMS alerts were delivered via Twilio with confirmation logic to minimize false alarms. Tests under normal, high turbidity, and low pH conditions showed accurate performance, with alerts triggered when pH fell outside 6–9 or turbidity exceeded 50 NTU. The system proved stable, low-cost, and scalable, offering practical applications for residential and community use. It supports early pollution detection, as emphasized by incidents like the Kim Kim River case. Future work will expand monitored parameters, add mobile app integration, and introduce automated sensor cleaning for improved usability.

Keywords: river water pollution, water quality monitoring, internet of things, real-time alert system

1. Introduction

Water is an essential resource for all living beings and plays a key role in maintaining the earth's natural balance. Malaysia is a privilege country to have abundant water resources considering the amount of the river spreads across the country. However, surface water pollution remains one of the main concerns of Malaysians. Based on the Malaysia 2023 Environmental Quality Report, where 672 rivers were monitored, revealing that 25 rivers were indicated as polluted river, 161 rivers as slightly polluted while the remaining rivers were indicated as clean river according to the standards [1]. Thus, a total of 28% of the monitored rivers were either polluted or slightly polluted, which does not guarantee safety of the environment and health of the life beings.

In 2023, 4 years after the tragic Kim Kim River pollution took place, there were reports relating to the victims of the polluted river [2]. One of the victims is suffering Myokymia which is due to the toxic waste exposure from the river while being at school [2]. The victim was exposed to toxic water due to the delay alert notification from the authorities at which pollution is only being detected when many residents fell ill. The 2019 incident of late detection and warning regarding the polluted Kim Kim River resulted into multiple consequences such as health crises and death of innocent lives.

The failure in monitoring the river water quality which causes delay in the detection of water pollution is contrary to the Sustainable Development Goals as suggested by the United Nations. It is specifically in contrast to SDG 6: Clean Water and Sanitation specifically target 6.3 which is to improve water quality by pollution reduction, dumping elimination and release of hazardous chemicals and materials into water bodies by 2030 [3]. In this case, when pollution is not identified properly, it causes significant risk in terms of health to the community. Besides that, failure to detect pollution also led to environmental degradation, especially the aquatic life in the affected river and the whole ecosystem nearby. Thus, to ensure SDG 6 is well achieved, water quality should be assessed all the time.

Pollution in water bodies can be identified by the assessment of water quality. The assessment of water quality focuses on the analysis of the characteristics of water which includes physical, chemical and biological characteristics [4]. A traditional way of water quality assessment is by examining many water samples in the laboratory which requires large amount of time and manpower. This method of water quality analysis does not support the idea of preventing the public residents from getting exposed to the toxic waste exposure through immediate analysis. In the age of technology, water quality monitoring systems are one of the required solutions to overcome such problems. Therefore, an IoT real-time water quality monitoring system with notification features are proposed in this paper. This system emphasizes less amount of manpower and time to conduct water quality assessments for monitoring system since it focuses on the interaction between the sensors, microcontroller, cloud platform and messaging applications.

2. Related Works

Water quality monitoring system is one of the growing technologies in maintaining a balanced ecosystem of the river. Theoretical review was conducted to obtain perspective on the existing system which are developed by other researchers. The review includes the technology used, water quality parameters measured and the functions. Zhang uses edge computing technique due to the wide range of bandwidth which reduces waste network bandwidth while the limitation includes storage of data collection failure when storage time is long [5]. On top of that, Zhang uses Raspberry Pi 3 which is low cost, compact, flexible and strong compatibility to the system. On the other hand, Govindasamy et al., uses WSN with GPS technology for the system where the IoT sensors are equipped with GPS information and uses ESP8266 due to the features of process-based nodes and has an affordable price [6].

Chowdury et al. applies WSN with neural network models in order to obtain high frequency and mobility while low power of the system by using Arduino Mega 2560 as the microcontroller [7]. Next, Forhad et al. uses the technique of integration between PLC and IoT where the communication protocol used was MODBUS TCP/IP [8]. The limitation of the system is it being too complex. Then, Jabbar et al., uses LoRaWAN technology in order to cover wide area of the environment of the study in rural area [9]. The limitation is it is not suitable for remote location since reliance on batteries for power supply. The system uses Arduino UNO Rev3 with solar panel to ensure the adaptability in rural areas. On the other hand, Pasika and Gandla uses Wi-Fi based IoT technology at which it uses MCU to interface the water quality parameters being that the microcontroller used is the Arduino Mega and ESP8266 Wi-Fi module [10]. Al Metwally et al., uses the function of IoT with additional feature of command to activate actuator such as warning and water filtration [11]. The microcontroller used in the system is Arduino UNO since it is cost effective and can operate various functions instantaneously.

Rajalashmi et al., uses GPRS networking protocol in order to operate the system while using Arduino Genuino 101 for the water quality monitoring system [12]. The use of GPRS is due to the function to locate the area on a specific location of bad water quality. Olatinwo and Joubert uses WPSN system and NOMA scheme in order to provide energy efficiency performance [13]. On contrary, Vasudevan and Baskaran, design the IoT system on USV which requires the use of GPS and GPRS connection to locate the position and real-time data to be sent into cloud [14]. This system uses Raspberry Pi since it is suitable to the function of the USV GPRS with IoT. Mohd Jais et al., developed the water quality monitoring system with alert mechanism using Arduino UNO Rev 3 with ESP8266 Wi-Fi module [15]. Lakshmikantha et al., also design the system with an integration with IoT and alert mechanism [16]. Apart from that, the system uses Arduino ATmega328 as the microcontroller since it has built-in ADC and Wi-Fi modules.

Then, Nishan et al., design the water quality monitoring system with Bluetooth modules using Arduino UNO since it easy to integrate using the Arduino IDE software [17]. Besides that, He et al., uses GNSS technology since the system built is using UAV at which GNSS is required to track the location of the UAV for real-time tracking as well as low power usage with the use of NB-IoT wireless module [18]. Murti et al., utilize LPWAN LoRa communication to transmit data in wide area while prioritizing the energy efficiency of the system and microcontroller used in the system is ATmega328P which plays a crucial role in the energy management [19]. The limitation of this system is it only sent the data to Android smartphone only. On top of that, Olanubi et al., design of water quality monitoring system is the integration of the system with IoT and control devices using ESP32 as the microcontroller [20]. The purpose of the system is to activate corrective action when water quality is poor [20]. On the other hand, this system only provides alert messages to internet-connected device. Prompt et al., uses the LoRa technology to be applied on long distance coverage which uses TTGO T-Beam ESP32 which operates at specific frequency [21].

Kumar et al., uses the technique of IoT integration with GIS and LoRaWAN connection at which location data is collected with the water quality parameters [22]. On top of that, Demetillo et al., uses the WSN technology with GSM communication while using electrochemical sensors [23]. The microcontroller used is Arduino Mega 2560 since it has a compact memory card for backup storage which is effective for WSN [23]. Shete et al., uses SIM800L GSM module for the communication in order to send the data to cloud server in real time [24]. Blanco Jáquez et al., uses LoRa communication protocol with LoRa repeater to extend the area of the LoRa communication [25]. Arduino Uno with LoRa Shield and Lilygo TTGO ESP32 LoRa Module was used in the system to ensure the operation of the extended feature [25]. Sudheer et al., integrate the IoT with Android device by using Arduino ATmega328P [26]. The limitation of this system is the non-Android device cannot use the function of the IoT of the system. Last but not least, Alam et al., design a low cost multi-parameter water quality monitoring system using electrochemical sensors by designing multi-layered PCB and the use of Arduino UNO microcontroller [27]. The system integrates with IoT as a smartphone application was developed to monitor real-time data [27].

Therefore, the proposed system used in this paper is using Wi-Fi connection via ESP32 with chosen parameters such as pH, turbidity and temperature. On top of that, solar panel is chosen as the component for power supply to ensure lifelong battery. This system focuses on low-cost water quality monitoring system with integration of IoT for real-time.

3. Methodology

The first stage of the project involves designing the overall system, as shown in Figure 1. The numbered sections in Figure 1 represent the three key functional sections of the system architecture. Based on section 1 (green), the chosen water quality sensors, such as pH, turbidity and temperature, collect data from the environment. The data received by the sensors are transmitted to microcontroller, which processes raw data to a processed data. Then, in section 2 (red), the processed data is sent to an IoT cloud platform via Wi-Fi connection. This IoT cloud platform is where the data is stored and visualized in real time or in other words aids in real-time monitoring. Lastly, in section 3 (yellow) the system compares the processed parameter reading with the threshold limits according to the NWQS to identify the status of the pollution. If the parameter is not within the threshold value, the system will automatically trigger an SMS alert to notify the user on the potential of river pollution.

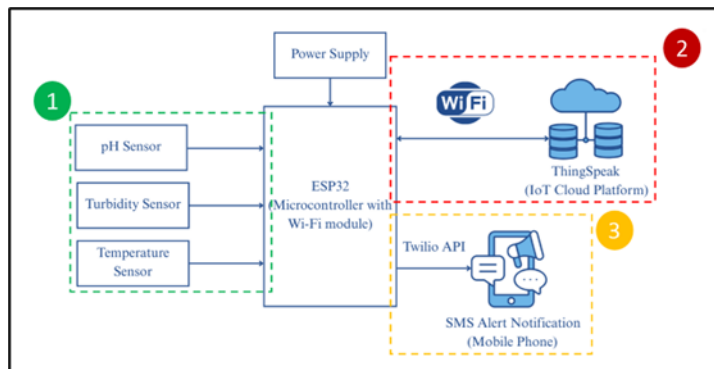

Figure 1. System architecture

3.1 Hardware Design

As the system mainly focuses on real time water quality monitoring, thus it requires multiple hardware components. The main components of the system are microcontroller, water quality parameter sensors and additional hardware component supports. The microcontroller used in this system is the ESP32 Wi-Fi module. This is due to its ability to transfer the data wirelessly via Wi-Fi connection. On the other hand, the sensors used are the pH sensor PH4502C, turbidity sensor AZDM01 and temperature sensor DS18B20. The sensor modules were chosen based on the characteristics of the module and compatibility with ESP32 microcontroller. Two 3.7V lithium batteries were used as the power supply of the system. Besides that, additional hardware components include ESP32 external antenna, expansion board, resistors, PVC housing and floats. The ESP32 external antenna is required to ensure ESP32 microcontroller can connect to Wi-Fi for data transmission and alert notification implementation. The hardware design includes a floating mechanism for the housing by utilizing floats and a PVC enclosure to ensure safe operation in aquatic environment.

3.2 Software Design

The software component plays a crucial role to manage the core operations of the IoT-enabled monitoring and notification system for real-time water quality management. The main software tools used in the project include Arduino IDE as the development tool, ThingSpeak as the IoT cloud platform and Twilio as the cloud communication API. Arduino IDE was chosen as the development tool due to its simplicity and user-friendly interface. In addition, it supports the ESP32 microcontroller due to the built-in additional board packages library which makes it easy to program using C language. Besides that, ThingSpeak was selected as the IoT cloud platform due to built-in tools for real-time data visualization and storage and the ease of integration with Arduino IDE. On top of that, Twilio was used for the alert generation to send SMS-based notifications to user. It is highly compatible with Arduino IDE due to the convenient accessed through HTTP request.

Although Twilio account needs to be upgraded to send more SMS, it is also one of the best solutions that does not require additional hardware component such as GSM module with SIM card. There is no restriction in sending SMS alerts to any registered phone number, regardless of the smartphone type. ThingSpeak and Twilio are one of the best choices in achieving the project objectives, especially with the feature of ESP32 which has a built in Wi-Fi module. This ensured that data can be sent to these applications when the system is connected to the internet.

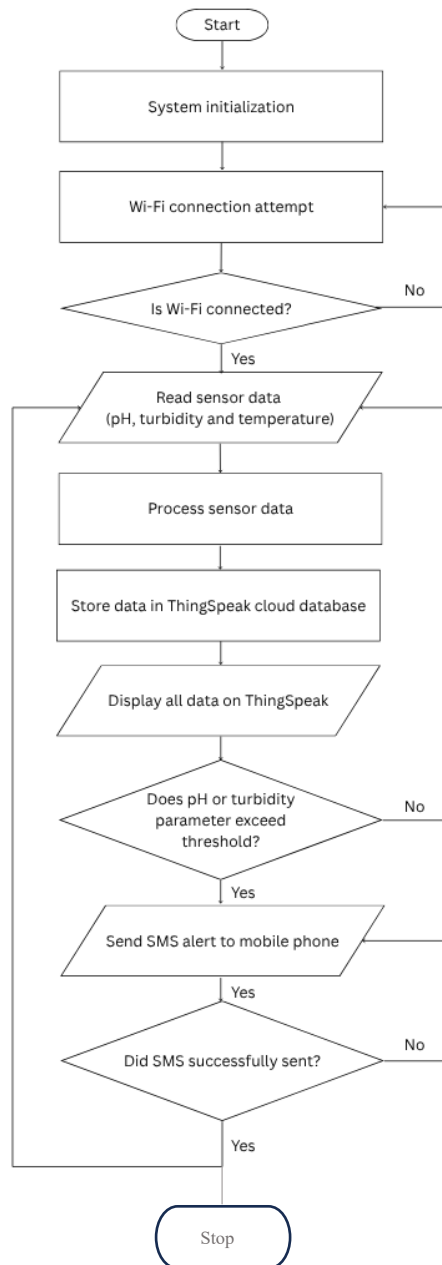

Figure 2. Overall system flowchart

Figure 2 shows the overall system flowchart where it begins with the initialization of ESP32, sensor pins and serial communication. Then, the system will connect to Wi-Fi for data transmission to ThingSpeak. The raw data from the pH, turbidity and temperature sensor are read and processed by ESP32 to obtain the processed data or also known as the actual parameters measured by the system. These processed data are sent to ThingSpeak cloud IoT platform for real-time monitoring and visualization. In addition, the processed data is also compared to the threshold for pH and turbidity parameter and polluted flag will be on if it exceeds the threshold. This polluted flag triggers the HTTP request to the Twilio API, which sends the SMS alert notification to user when pollution is detected. If no pollution is detected no SMS alert notification is sent. The system operates in a continuous loop to enable continuous real-time monitoring.

3.3 Data Acquisition Implementation

Data acquisition is a critical stage in the project, where water quality data is collected, processed and prepared for the transmission. This stage begins with the integration of the sensors with ESP32 microcontroller. Then, ESP32 is programmed via Arduino IDE to convert raw data obtained from the sensors into processed data. It is followed by calibration of the sensors raw and processed data to ensure the accuracy of the readings with the expected outcome. These

processed values are then prepared to be used for cloud transmission and pollution detection in the next stage. Figure 3 shows the flowchart of the data acquisition mechanism in the system which is programmed in the ESP32. Figure 4 illustrates the wiring connection of ESP32 with sensors according to the pin assignments.

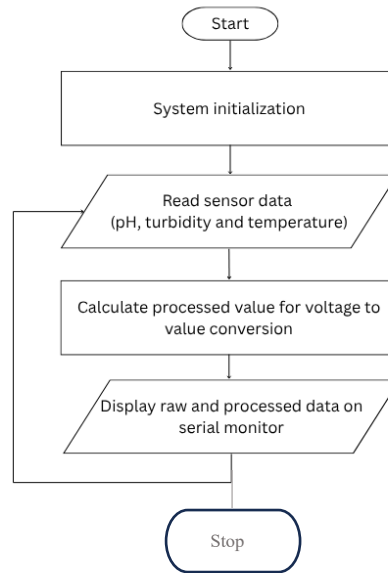

Figure 3. Flowchart of the data acquisition mechanism

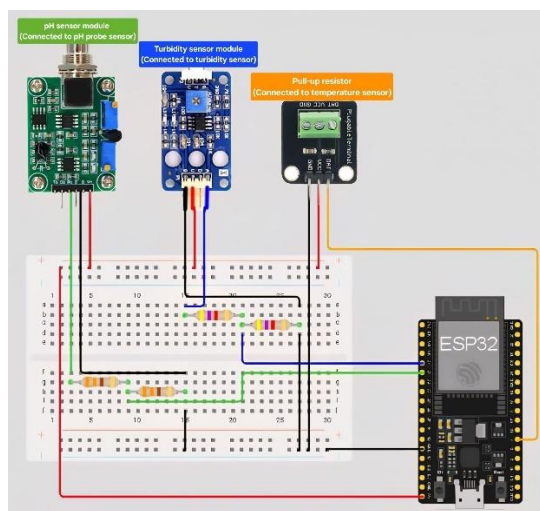

Figure 4. Circuit design for sensors connection with ESP32

4. Results and Discussion

4.1 Normal River Water Condition

Figure 5 shows the system during deployment in a calm and clear section of the river. The waterproof enclosure containing the ESP32 microcontroller and sensors is securely placed on a floating house, tethered near the riverbank to prevent drifting. The water appears clean with minimal suspended particles, and the sensors remain fully submerged for stable data collection. This setup reflects typical conditions with no visible contamination or disturbance in the surrounding environment.

A total of 20 samples collected over a 1 hour and 30-minute monitoring period, with readings taken at three-minute intervals. Throughout the session, all recorded pH values were within the safe range of 6 to 9, and turbidity readings remained consistently low, well below the 50 NTU threshold. The temperature readings were also stable, which approximately 28°C, showing no environmental anomalies. Based on these conditions, the pollution flag remained

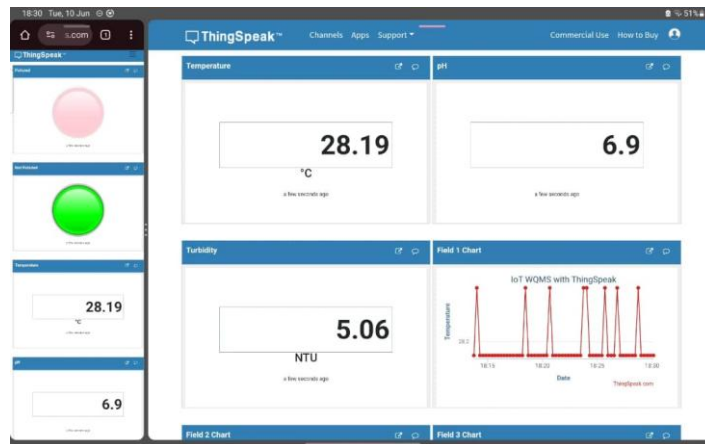

Figure 8. ThingSpeak interface of the 20th timestamp

4.2 High Turbidity Water Condition

Figure 9 shows the system floating in murky river water following a rain event. The water appears cloudy and brownish due to the presence of suspended soil and organic matter. Despite the change in water clarity, the hardware remains intact, with sensors submerged and actively collecting turbidity data.



Figure 9. System deployed in high turbidity river water

Despite pH and temperature remaining within acceptable limits, the turbidity values exceeded the set threshold of 50 NTU starting from the first timestamp. As a result, the system immediately entered into confirmation mode. In the second timestamp, the pollution flag was on. The pollution flag was active throughout the next timestamp in this case except for confirmation period.

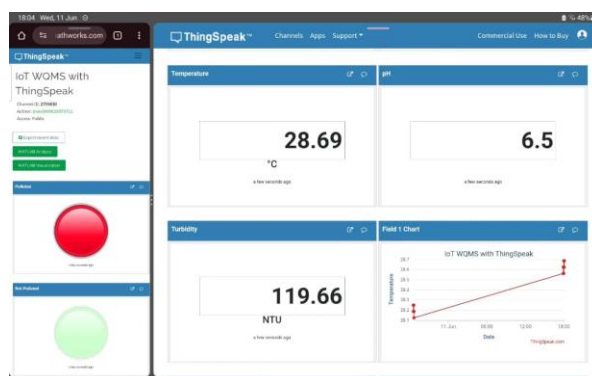

Figure10. ThingSpeak interface of the 2nd timestamp

As shown in Figure 10, 2nd timestamp records a turbidity value of 119.66 NTU, which exceeds the safe threshold, while pH is 6.4 and temperature is 28.69°C. The red indicator is triggered, indicating polluted water due to high turbidity. In Figure 11, the 11th sample continues to show high turbidity at 128.76 NTU, confirming that the pollution persists, even after 33 minutes. In Figure 12, the 20th sample records turbidity as 128.10 NTU, reinforcing the presence of suspended particles or sediment. The pollution flag remains active throughout the period except during the confirmation mode. The ThingSpeak visualizations validate the system's ability to detect and react appropriately to the abnormal quality parameter in water clarity.

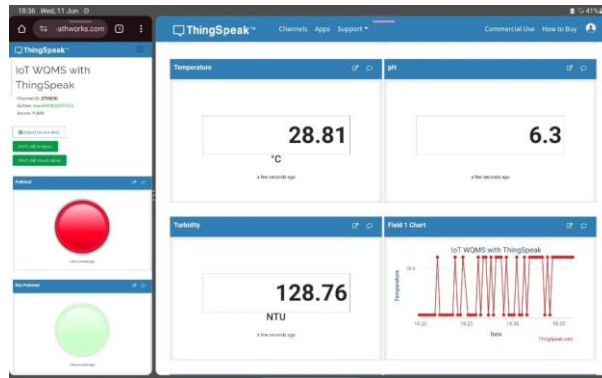

Figure 11. ThingSpeak interface of the 11th timestamp

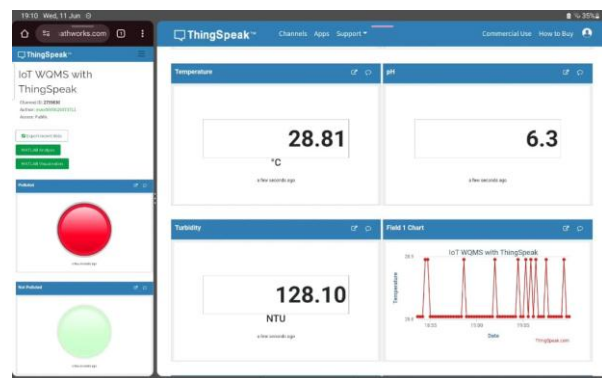

Figure 12. ThingSpeak interface of the 20th timestamp

5. Conclusions

This study successfully demonstrated consistent and reliable performance throughout all three test scenarios. It successfully monitored pH, turbidity, and temperature values in real time, accurately identifying deviations from the acceptable water quality thresholds. Abnormal conditions, such as turbidity exceeding 50 NTU or pH values outside the range of 6–9, were promptly detected, triggering the alert mechanism without delay. The integration of ThingSpeak enabled seamless cloud-based data transmission, storage, and visualization, while the Twilio API provided an efficient and automated SMS notification service to end users. The confirmation logic built into the system ensured that false alarms were minimized, enhancing their practicality for real-world use.

For system validation, 20 timestamped samples were collected over a 90-minute duration for each scenario, which offered sufficient temporal resolution to assess both short-term fluctuations and sustained changes in water quality. The data logs confirmed that under normal conditions, the system-maintained stability by continuously recording without unnecessary alerts, while under pollution scenarios, it responded quickly and consistently. This balance between sensitivity and stability highlights the robustness of the proposed design and its potential for deployment in residential areas, small communities, and environmental monitoring projects where continuous and reliable water quality surveillance is critical.

Acknowledgment

The authors would like to thank the Universiti Teknologi Malaysia (UTM) and Hasanuddin University for funding this research with Vote No. 04M88 and 4B914.

References

- [1] M. Department of Environment, "Environmental Quality Report 2023," 2022. [Online]. Available: <https://edl.doc.gov.my/epub?p=wV8DYR82bhST8C07kZFtKBdrIOgtLofbxlrgOYcGHdXTmVjnXdF3AKbJ4BQlzVj0RPov2aWy%2B2KEHhYs3L9U%2BdKufBhWkNQIbSsoky7zpnL%2FBfcH%2B6PjXbd1GaVCRY0dvZJigxsqZe%2BJ42oehygBTQ%3D%3D>
- [2] M. F. Noh, "Sg Kim Kim pollution: Victim still suffering from impact on health, villagers decry forgotten promises," in *New Straits Times*, ed. Johor Bahru: NST, 2023.
- [3] U. Nation. "Ensure availability and sustainable management of water and sanitation for all." United Nation Department of Economic and Social Affairs. <https://sdgs.un.org/goals/goal6>
- [4] D. V. Chapman, O. World Health, Unesco, and P. United Nations Environment, "Water quality assessments : a guide to the use of biota, sediments and water in environmental monitoring / edited by Deborah Chapman," 2nd ed. London: E & FN Spon, 1996.
- [5] Y. Zhang, "Intelligent Treatment Strategy of Water Quality Monitoring Node Based on Edge Computing," presented at the Proceedings of the 2024 International Conference on Machine Intelligence and Digital Applications, Ningbo, China, 2024. [Online]. Available: <https://doi.org/10.1145/3662739.3672319>.
- [6] M. Govindasamy, K. Jayanthi, and S. Rajagopan, "IoT Product on Smart Water Quality Monitoring System (Iot Wq-Kit) for Puducherry Union Territory," in *2023 Second International Conference on Advances in Computational Intelligence and Communication (ICACIC)*, 7-8 Dec. 2023 2023, pp. 1-5, doi: 10.1109/ICACIC59454.2023.10435019.
- [7] M. S. U. Chowdury *et al.*, "IoT Based Real-time River Water Quality Monitoring System," *Procedia Computer Science*, vol. 155, pp. 161-168, 2019/01/01/ 2019, doi: <https://doi.org/10.1016/j.procs.2019.08.025>.
- [8] H. M. Forhad *et al.*, "IoT based real-time water quality monitoring system in water treatment plants (WTPs)," *Heliyon*, vol. 10, no. 23, p. e40746, 2024/12/15/ 2024, doi: <https://doi.org/10.1016/j.heliyon.2024.e40746>.
- [9] W. A. Jabbar *et al.*, "Development of LoRaWAN-based IoT system for water quality monitoring in rural areas," *Expert Systems with Applications*, vol. 242, p. 122862, 2024/05/15/ 2024, doi: <https://doi.org/10.1016/j.eswa.2023.122862>.
- [10] S. Pasika and S. T. Gandla, "Smart water quality monitoring system with cost-effective using IoT," *Heliyon*, vol. 6, no. 7, p. e04096, 2020/07/01/ 2020, doi: <https://doi.org/10.1016/j.heliyon.2020.e04096>.
- [11] S. A. H. AlMetwally, M. K. Hassan, and M. H. Mourad, "Real Time Internet of Things (IoT) Based Water Quality Management System," *Procedia CIRP*, vol. 91, pp. 478-485, 2020/01/01/ 2020, doi: <https://doi.org/10.1016/j.procir.2020.03.107>.
- [12] K. Rajalashmi, N. Yugathian, S. Monisha, and N. Jeevitha, "IoT based water quality management system," *Materials Today: Proceedings*, vol. 45, pp. 512-515, 2021/01/01/ 2021, doi: <https://doi.org/10.1016/j.matpr.2020.02.110>.
- [13] S. O. Olatinwo and T.-H. Joubert, "Energy efficiency maximization in a wireless powered IoT sensor network for water quality monitoring," *Computer Networks*, vol. 176, p. 107237, 2020/07/20/ 2020, doi: <https://doi.org/10.1016/j.comnet.2020.107237>.
- [14] S. K. Vasudevan and B. Baskaran, "An improved real-time water quality monitoring embedded system with IoT on unmanned surface vehicle," *Ecological Informatics*, vol. 65, p. 101421, 2021/11/01/ 2021, doi: <https://doi.org/10.1016/j.ecoinf.2021.101421>.
- [15] N. A. Mohd Jais, A. F. Abdullah, M. S. Mohd Kassim, M. M. Abd Karim, A. M, and N. A. Muhadi, "Improved accuracy in IoT-Based water quality monitoring for aquaculture tanks using low-cost sensors: Asian seabass fish farming," *Heliyon*, vol. 10, no. 8, p. e29022, 2024/04/30/ 2024, doi: <https://doi.org/10.1016/j.heliyon.2024.e29022>.
- [16] V. Lakshmikantha, A. Hiriyannagowda, A. Manjunath, A. Patted, J. Basavaiah, and A. A. Anthony, "IoT based smart water quality monitoring system," *Global Transitions Proceedings*, vol. 2, no. 2, pp. 181-186, 2021/11/01/ 2021, doi: <https://doi.org/10.1016/j.gltip.2021.08.062>.
- [17] R. K. Nishan, S. Akter, R. I. Sony, M. M. Hoque, M. J. Anee, and A. Hossain, "Development of an IoT-based multi-level system for real-time water quality monitoring in industrial wastewater," (in English), *Discover Water*, vol. 4, no. 1, p. 43, Dec 2024 2024-07-10 2024, doi: <https://doi.org/10.1007/s43832-024-00092-y>.

- [18] Y. He, Y. Yang, T. He, Y. Lai, Y. He, and B. Chen, "Small and Micro-Water Quality Monitoring Based on the Integration of a Full-Space Real 3D Model and IoT," (in English), *Sensors*, vol. 24, no. 3, p. 1033, 2024
2024-08-27 2024, doi: <https://doi.org/10.3390/s24031033>.
- [19] M. A. Murti, A. R. A. Saputra, I. Alinursafa, A. N. Ahmed, A. Yafouz, and A. El-Shafie, "Smart system for water quality monitoring utilizing long-range-based Internet of Things," (in English), *Applied Water Science*, vol. 14, no. 4, p. 69, Apr 2024
2024-10-03 2024, doi: <https://doi.org/10.1007/s13201-024-02128-z>.
- [20] O. O. Olanubi, T. T. Akano, and O. S. Asaolu, "Design and development of an IoT-based intelligent water quality management system for aquaculture," (in English), *Journal of Electrical Systems and Information Technology*, vol. 11, no. 1, p. 15, Dec 2024
2024-08-27 2024, doi: <https://doi.org/10.1186/s43067-024-00139-z>.
- [21] S. Prompt, S. Maithomklang, and C. Panya-isara, "Design and Analysis Performance of IoT-Based Water Quality Monitoring System using LoRa Technology," (in English), *TEM Journal*, vol. 12, no. 1, pp. 29-35, Feb 2023
2024-12-05 2023, doi: <https://doi.org/10.18421/TEM121-04>.
- [22] P. K. Kumar, L. Priyanka, K. Saritha, S. Deepika, and R. Suma, "GIS Constructed Water Monitoring Network System Via IOT," (in English), *Journal of Electrical Systems*, vol. 20, no. 2, pp. 2671-2678, 2024
2024-07-01 2024.
- [23] A. T. Demetillo, M. V. Japitana, and E. B. Taboada, "A system for monitoring water quality in a large aquatic area using wireless sensor network technology," *Sustainable Environment Research*, vol. 29, no. 1, p. 12, 2019/04/23 2019, doi: 10.1186/s42834-019-0009-4.
- [24] R. P. Shete, A. M. Bongale, and D. Dharrao, "IoT-enabled effective real-time water quality monitoring method for aquaculture," *MethodsX*, vol. 13, p. 102906, 2024/12/01/ 2024, doi: <https://doi.org/10.1016/j.mex.2024.102906>.
- [25] A. D. Blanco Jáquez, M. T. Alarcon Herrera, A. E. Marín Celestino, R. Efraín Neri, and D. A. Martínez Cruz, "Extension of LoRa Coverage and Integration of an Unsupervised Anomaly Detection Algorithm in an IoT Water Quality Monitoring System," (in English), *Water*, vol. 15, no. 7, p. 1351, 2023
2024-09-04 2023, doi: <https://doi.org/10.3390/w15071351>.
- [26] K. Sudheer, S. Koteswararao, P. D. Matcha, D. Sunil, and A. Professor, "IoT-BASED SYSTEM FOR MONITORING WATER QUALITY," *Turkish Journal of Computer and Mathematics Education*, vol. Vol.14 No.03 (2023), 2023.
- [27] M. Alam, M. M. Islam, N. M. Nayan, and J. Uddin, "An IoT Based Real-Time Environmental Monitoring System for Developing Areas," *Journal of Advanced Research in Applied Sciences and Engineering Technology*, Article vol. 52, no. 1, pp. 106-121, 2025, doi: 10.37934/araset.52.1.106121.